

Install the lock between the door edge and the handle to avoid obstructing the overhead clearance and creating safety hazards. Check inside the door for rivets, bolts or brackets that could hinder proper lock placement. Inspect under the truck floor deck for any obstructions that might make installation difficult.

After this inspection and selecting the lock location, drill a pilot hole exactly 3 5/8" up from the bottom of the door (including the rubber gasket).

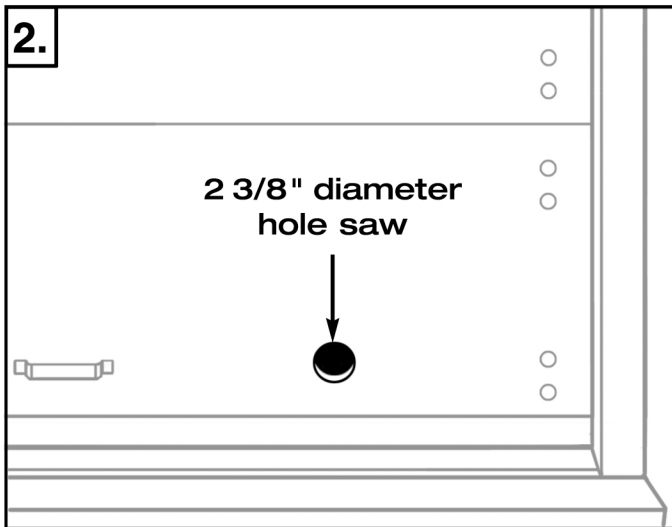

Using the pilot hole as the center, drill a 2 3/8" diameter hole using a standard hole saw.

This hole may have to go through the heavy metal angle brace in some doors. If the hole saw won't cut through the metal, a torch or grinder and chisel may have to be used to remove the obstruction.

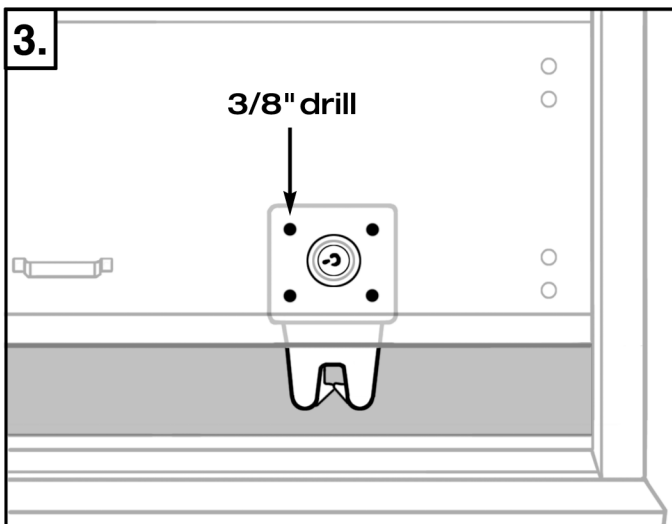

Working from the back of the door, place the lock in the hole. Check the lock plate is perpendicular and square with the bottom of the door and mark one of the top holes.

Drill the hole using a 3/8" drill bit. Install the carriage bolt from the outside of the door. Position the lock washer, check the assembly has remained square and tighten the nut.

Using the same procedure drill the remaining top hole, secure the bolt, then drill, insert and tighten the bottom two bolts.

Roll-up door lock 8050 INSTRUCTIONS FOR INSTALLATION

2.

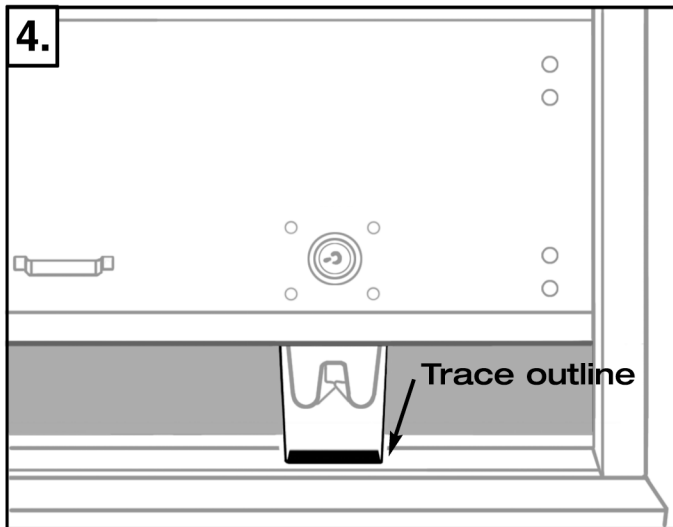

Assemble the base pin assembly on the lock plate. Lower the door to place the base on the sill and move it from side to side to determine the medium position.

Outline the base position on the sill with marker or chalk. Check again under the deck for wiring or other obstructions.

Use a torch or plasma cutter to remove the outlined section of material to allow the base pin assembly to fit down into the deck.

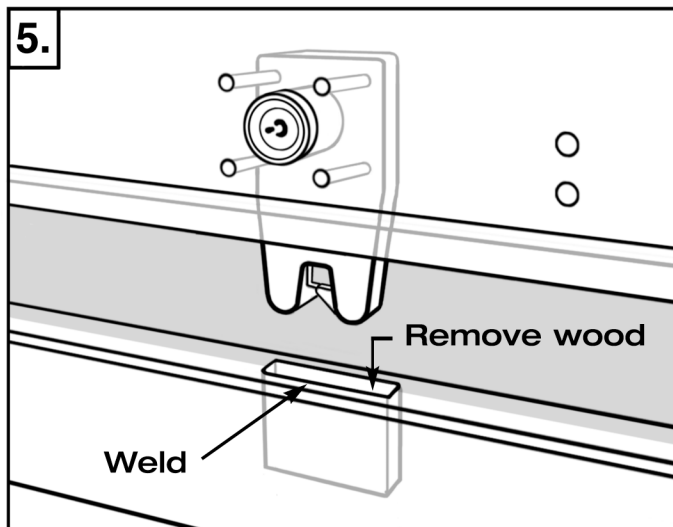

Some installations may require removing a small portion of the wood floor overlapped by the sill. For installations on aluminum decks aluminum boots are available.

Tack weld the base pin assembly in place and thoroughly check the lock's operation.

When satisfied the base is located properly for the lock's effective operation, complete the weld. In some applications it may be necessary to weld from underneath the deck to achieve maximum assembly strength.

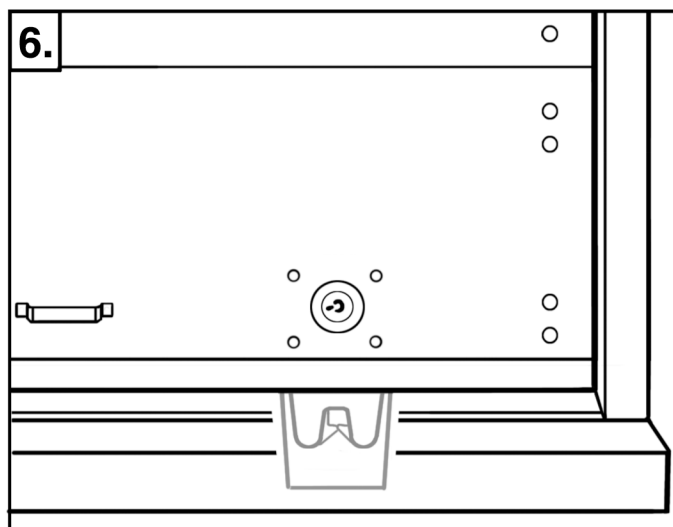

Recheck the lock's smooth operation. Stamp the truck number on the keys and store them in a safe place.

The door must be completely closed for the lock to open. Exerting upward pressure on the handle will only cause the internal hooks to grasp the base pins tighter and keep the lock from opening.